

# RECORD OF RESOLUTION

Resolution No. 2024-R-09 Passed July 1, 2024  
YEAR

VILLAGE COUNCIL OF NORTH FAIRFIELD, OHIO  
RESOLUTION NO.: 2024-R-09

A RESOLUTION ACCEPTING THE QUOTE AND AUTHORIZING THE VILLAGE ADMINISTRATOR TO ENTER INTO AN AGREEMENT WITH NORWALK CONCRETE TO SUPPLY TWO CATCH BASINS AND DECLARING AN EMERGENCY

WHEREAS, the Village Administrator has requested quotes for the supply of two catch basins; and

WHEREAS, the Village Administrator reports that the lowest and best quote was received from Norwalk Concrete dated Friday, June 28, 2024, with an Order Date of 6/21/2024; and

WHEREAS, the Village Administrator is seeking authorization from Council to enter into an agreement with the lowest and best proposal.

NOW THEREFORE, BE IT RESOLVED BY THE COUNCIL OF THE VILLAGE OF NORTH FAIRFIELD, STATE OF OHIO: (RC 731.18)

SECTION 1. ACCEPT QUOTE. Village Council hereby accepts the quote of Norwalk Concrete dated Friday, June 28, 2024, with an Order Date of 6/21/2024, Quote # 24-3347 as the lowest and best proposal. [ATTACHED HERETO AND INCORPORATED HEREIN BY REFERENCE]

SECTION 1. AUTHORIZATION. That the Village Administrator is hereby authorized to enter into Agreement with Norwalk Concrete for the supply of two catch basins pursuant to the quote dated Friday, June 28, 2024, with an Order Date of 6/21/2024 not to exceed \$1,010.00.

SECTION 3. DISPENSE WITH THREE READINGS. That the legislative authority, upon a vote of at least three-fourths of its members, hereby dispenses with the rule requiring each ordinance or resolution shall be read on three different days. [R.C. 731.17(A)(2)]

SECTION 4. DECLARATION OF EMERGENCY FOR IMMEDIATE EFFECT. That by two-thirds vote of all the members elected to the legislative authority, this Ordinance/Resolution is hereby declared to be an emergency measure pursuant to RC 731.30, being necessary for the immediate preservation of the public peace, health, or safety of the municipal corporation and shall go into immediate effect for the following reason(s):

*The quoted price for installation from another vendor is valid for only 60 days.*

SECTION 5. PUBLIC MEETING. That it is found and determined that all formal action of this public body concerning or relating to the passage of this Resolution/Ordinance were adopted in a public meeting open to the public at all times, and that all deliberations of the public body and any of its committees that resulted in such formal action, were in public meetings open to the public, in compliance with all legal requirements including all lawful ordinances and any applicable provisions of section 121.22 of the Ohio Revised Code.

WHEREFORE, this legislation shall be in full force and effect from and after the earliest period allowed by law.

PASSED AND ADOPTED on this 1 day of July, 2024.

# RECORD OF RESOLUTION

Resolution No. 2024-R-09

Passed July 1, 2024  
YEAR

## ATTESTATION

(RC 731.20)

We hereby attest and affirm that the foregoing legislation received the necessary affirmative roll call votes required for passage by R.C. 731.17.

[Signature]  
MAYOR

[Signature]  
FISCAL OFFICER

## LEGISLATION READINGS

ORC 731.17(A)

- (1) Each ordinance and resolution shall be read by title only, provided the legislative authority may require any reading to be in full by a majority vote of its members.  
(2) Each ordinance or resolution shall be read on three different days, provided the legislative authority may dispense with this rule by a vote of at least three-fourths of its members.

First Reading: 7/1/24 Second Reading: Dispensed Third Reading: Dispensed

## ROLL CALL VOTE

ORC 731.17(A)(3)

The vote on the passage was taken by yeas and nays and entered upon the journal. Each ordinance or resolution shall be passed, except as otherwise provided by law, by a vote of at least a majority of all the members of the legislative authority. Yeas, nays, abstentions, excused or absent votes were recorded as follows:

[Signature]  
Adam Rouse

[Signature]  
Sharleen Coy

[Signature]  
Jeremy Antil

[Signature]  
Cody Black

[Signature]  
Trevor Arnold

[Signature]  
Joshua Radcliffe

PREPARED BY AND APPROVED AS TO FORM [See also RC 731.21(B)]:

[Signature]  
VILLAGE SOLICITOR, Steve Palmer

## CERTIFICATE OF PUBLICATION

ORC 731.21 and 731.22

Pursuant to ORC 731.21(A)(3), I hereby certify that a succinct summary of the above legislation was/will be published using the following method: **ON THE WEBSITE AND SOCIAL MEDIA ACCOUNT OF THE MUNICIPAL CORPORATION**

The succinct summary was reviewed by the village solicitor as required by ORC 731.21(B). Publication was/will be made at least once a week for two consecutive weeks as required by ORC 731.22.

[Signature]  
FISCAL OFFICER

ATTACHMENT(S) TO FOLLOW



Norwalk Concrete Industries  
 80 Commerce Drive  
 Norwalk, OH 44857  
 Phone: (419) 668-8167  
 Fax: (419) 663-0627

**QUOTE**

Quote #: 24-3347      Terms: NET 30  
 Order Date: 6/21/2024

Village of North Fairfield

<b>Bill to:</b> Village of North Fairfield 3 E. Main, PO Box 188 North Fairfield, OH 44855	<b>Delivery to:</b> Huron-North Fairfield-Catch Basins 062024 3 E. Main Street North Fairfield, OH 44855
<b>Contact:</b> Tom Leto	<b>Project Manager:</b> Tom Leto
<b>Phone :</b> 419/744-2235 <b>Fax:</b>	<b>Phone :</b> (419) 541-7539 <b>Fax:</b>
<b>Customer ID:</b> NORTHF <b>PO:</b>	<b>ShipVia:</b> <b>Sales Rep:</b> Brian U

Qty	Item	Description	Weight	Unit F/H	Unit Price	TX	Extension
<b>Structure:</b> <input type="checkbox"/> <b>CB 2x2x3 KO</b> <b>Station:</b>							
2.00	CB242436KO1L	CB 24 x 24 x 36 w/ knockouts and concrete sill	4,600	\$0.00	\$225.00	<input type="checkbox"/>	\$450.00
							\$450.00
<hr/>							
<b>Structure:</b> <input type="checkbox"/> <b>CB Top 2-2</b> <b>Station:</b>							
2.00	CBT22B	Standard 2-2B Top	750	\$0.00	\$75.00	<input type="checkbox"/>	\$150.00
							\$150.00
<hr/>							
<b>Structure:</b> <input type="checkbox"/> <b>Grate 5110 M3</b> <b>Station:</b>							
2.00	9EJ5110M3	EJ 5110 M3 Grate (00511043)	318	\$0.00	\$205.00	<input type="checkbox"/>	\$410.00
							\$410.00

**Total Weight**      5,668

<b>Taxable</b>	\$0.00
<b>Non-Taxable</b>	\$1,010.00
<b>Sub Total</b>	\$1,010.00
<b>Tax</b>	\$0.00
<b>Total</b>	\$1,010.00

**Delivered and Offloaded at Jobsite**

We Propose hereby to furnish material and labor--complete in accordance with the above specification.  
 Payment to be made as follow s: NET 30 Days Billed Monthly Based on quantity produced. NO TAXES INCLUDED.

**See Final Page for NCI Standard Terms and Conditions**



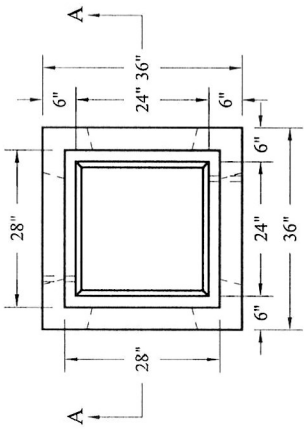

CATCH BASIN PLAN VIEW

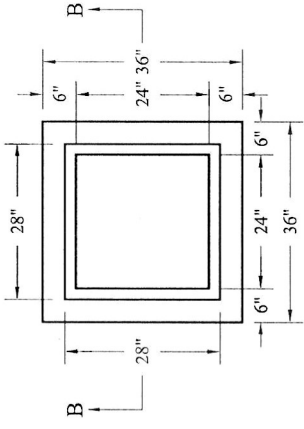

INTERLOCKING RISER PLAN VIEW

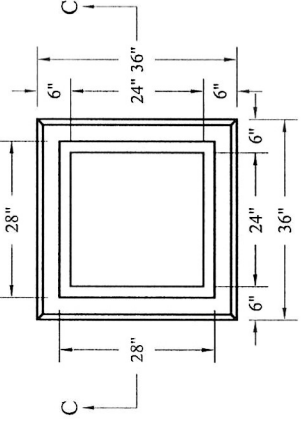

TOP PLAN

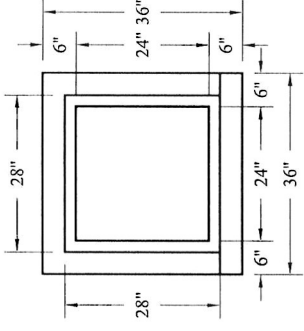

SLANT TOP PLAN VIEW

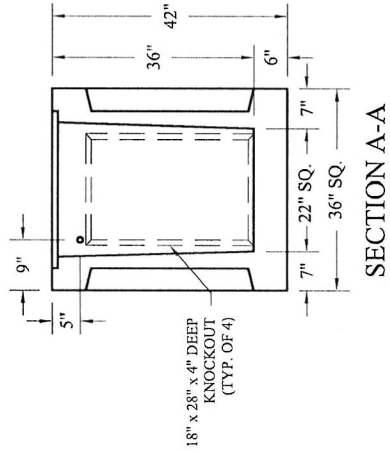

SECTION A-A

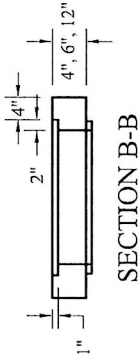

SECTION B-B

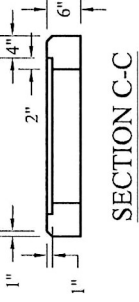

SECTION C-C

PIECE PART	HEIGHT	WEIGHT
CATCH BASIN	36"	2,300 LBS.
INTERLOCKING RISERS	4"	250 LBS.
	6"	375 LBS.
	12"	750 LBS.
TOP	6"	375 LBS.
SLANT TOPS	4" @ 15"	560 LBS.
	6" @ 17"	685 LBS.
	12" @ 23"	1,060 LBS.

SLANT TOP FRONT VIEW

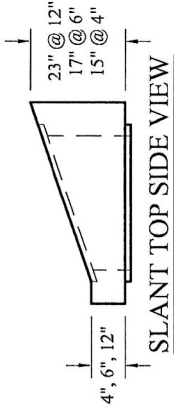

SLANT TOP SIDE VIEW

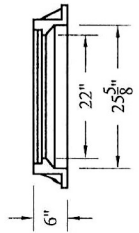
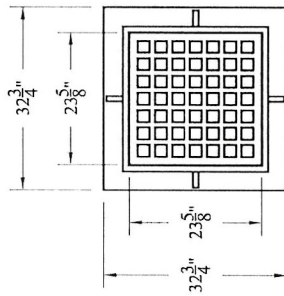

EJIW 5250 FRAME AND GRATE

(FRAME = 165 LBS., GRATE = 162 LBS.)

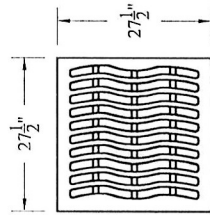

EJIW 5110 M-3 GRATE  
1" THICK (165 LBS.)

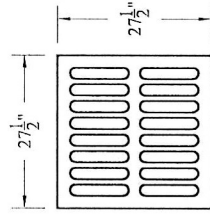

EJIW 5110 M-2 GRATE  
1" THICK (144 LBS.)

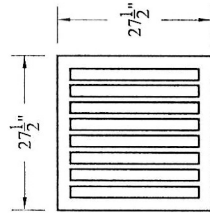

EJIW 5110 M-1 GRATE  
1" THICK (120 LBS.)

**NCI**

Norwalk Concrete Industries  
80 Commerce Drive  
Norwalk, Ohio 44857  
www.nciprecast.com  
Toll Free 800.733.3624  
Phone 419.668.8167  
Fax 419.663.0627

MODULAR CATCH BASIN  
2' x 2' x 3' I.D. WITH  
KNOCKOUTS

REVISIONS:  
08-03-06

DWG. NO. D-0002-02  
DATE 02-18-02

SHT. -  
OF -  
JDH

CAST IRON OPTIONS